

STN1110

Multiprotocol OBD to UART Interpreter Datasheet

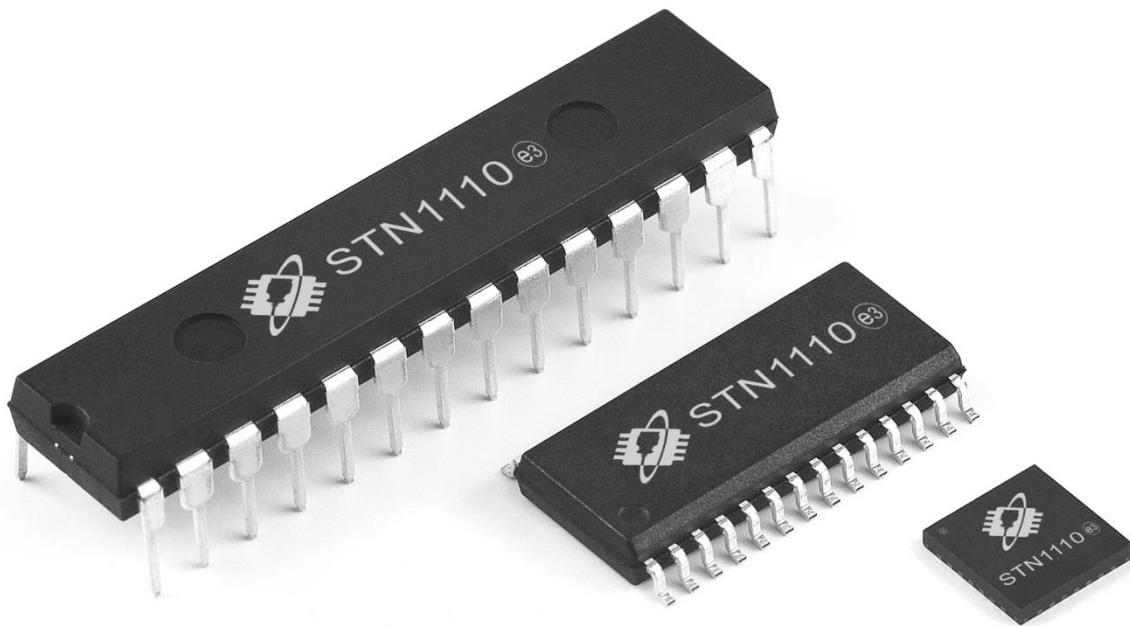

Table of Contents

1.0	Overview	4
2.0	Feature Highlights	4
3.0	Typical Applications	4
4.0	Pinout	5
4.1	Pinout Summary	6
4.2	Detailed Pin Descriptions	7
5.0	Guidelines for Getting Started with STN1110	10
5.1	Basic Connection Requirements	10
5.2	Decoupling Capacitors	10
5.3	Tank Capacitors	10
5.4	AVDD and AVSS Pins	10
5.5	Internal Voltage Regulator Filter Capacitor	10
5.6	Oscillator Pins	10
5.7	Device Reset Pin	11
5.8	NVM Reset Input	11
5.9	Power and Sleep Considerations	11
5.10	Open Drain Outputs	11
5.11	Unused Inputs and Unused Open Drain Outputs	11
6.0	Reference Schematics	12
6.1	Recommended Minimum Connection	12
6.2	Typical Configuration	13
6.2.1	STN1110 IC	13
6.2.2	Voltage Sense	14
6.2.3	LEDs	15
6.2.4	OBD Port Connector and ESD protection	15
6.2.5	Overvoltage Protection Circuit	16
6.2.6	Power Supplies	17
6.2.7	Switched Power Control	17
6.2.8	ISO 9141/ISO 14230 Transceiver	18
6.2.9	High-Speed CAN Transceiver	19
6.2.10	Alternative (MCP2551) HS-CAN Transceiver	19
6.2.11	SAE J1850 Transceiver	20
7.0	Electrical Characteristics	22
7.1	Absolute Maximum Ratings	22
7.2	Electrical Characteristics	22
8.0	Packaging Diagrams and Parameters	25
8.1	SPDIP (SP) Package	25
8.2	SOIC 300mil (SO) Package	26
8.3	SOIC 300mil (SO) Land Pattern	27
8.4	QFN-S (MM) Package	28
8.5	QFN-S (MM) Land Pattern	29
9.0	Ordering Information	30
Appendix A:	Revision History	31
Appendix B:	Contact Information	32

TO OUR VALUED CUSTOMERS

It is our intention to provide our valued customers with the best documentation possible to ensure successful use of your OBD Solutions products. To this end, we will continue to improve our publications to better suit your needs. Our publications will be refined and enhanced as new volumes and updates are introduced.

Most Current Data Sheet

To obtain the most up-to-date version of this data sheet, please visit our web site at <http://www.obdsol.com>

You can determine the version of a data sheet by examining its literature number found on the bottom outside corner of any page. The last character of the literature number is the version number, (e.g., STN1110DSA is version A of document STN1110DS).

All rights Reserved. Copyright © 2018 OBD Solutions

Every effort is made to verify the accuracy of information provided in this document, but no representation or warranty can be given and no liability assumed by OBD Solutions with respect to the accuracy and/or use of any products or information described in this document. OBD Solutions will not be responsible for any patent infringements arising from the use of these products or information, and does not authorize or warrant the use of any OBD Solutions product in life support devices and/or systems. OBD Solutions reserves the right to make changes to the device(s) described in the document in order to improve reliability, function, or design.

1.0 Overview

This datasheet summarizes the features of the STN1110 device. It is not intended as a comprehensive reference source. To complement the information in this datasheet, refer to the **OBLink® Family Reference and Programming Manual (FRPM)**. We encourage you to download the latest FRPM from the OBD Solutions website (www.obdsol.com).

The STN1110 is an OBD to UART interpreter IC designed to provide bi-directional half-duplex communication with the vehicle's On-Board Diagnostic System (OBD-II). It supports all legislated OBD-II protocols

A wealth of information can be obtained by tapping into the OBD bus, including the status of the malfunction indicator light (MIL), diagnostic trouble

codes (DTCs), inspection and maintenance (I/M) information, freeze frames, VIN, hundreds of real-time parameters, and more.

The STN1110 is fully compatible with the *de facto* industry standard ELM327 command set. Based on a 16-bit processor core, the STN1110 offers more features and better performance than any other ELM327 compatible IC.

2.0 Feature Highlights

- **Stable, field-tested firmware**
- Fully **compatible with the ELM327** AT command set
- **Extended ST command set**
- **UART interface** (baud rates from 38 bps to 10 Mbps¹)
- Secure **bootloader** for easy firmware updates
- Support for **all legislated OBD-II protocols**:
 - ISO 15765-4 (CAN)
 - ISO 14230-4 (Keyword Protocol 2000)
 - ISO 9141-2 (Asian, European, Chrysler vehicles)
 - SAE J1850 VPW (GM vehicles)
 - SAE J1850 PWM (Ford vehicles)
- Support for **non-legislated OBD protocols**:
 - ISO 15765
 - ISO 11898 (raw CAN)
- Support for the heavy-duty **SAE J1939 OBD protocol**
- Superior **automatic protocol detection** algorithm
- **Large memory buffer**
- Sophisticated **PowerSave Sleep/Wakeup Triggers**
- Available in **SPDIP, SOIC** and **QFN-S** packages
- **RoHS** compliant

Note 1: Maximum theoretical baud rate. Actual maximum baud rate is application dependent and may be limited by driver hardware.

3.0 Typical Applications

- Vehicle telematics
- Fleet management and tracking applications
- Usage-based insurance (UBI)
- OBD data loggers
- Automotive diagnostic scan tools and code readers
- Digital dashboards

4.0 Pinout

28-Pin SPDIP, SOIC

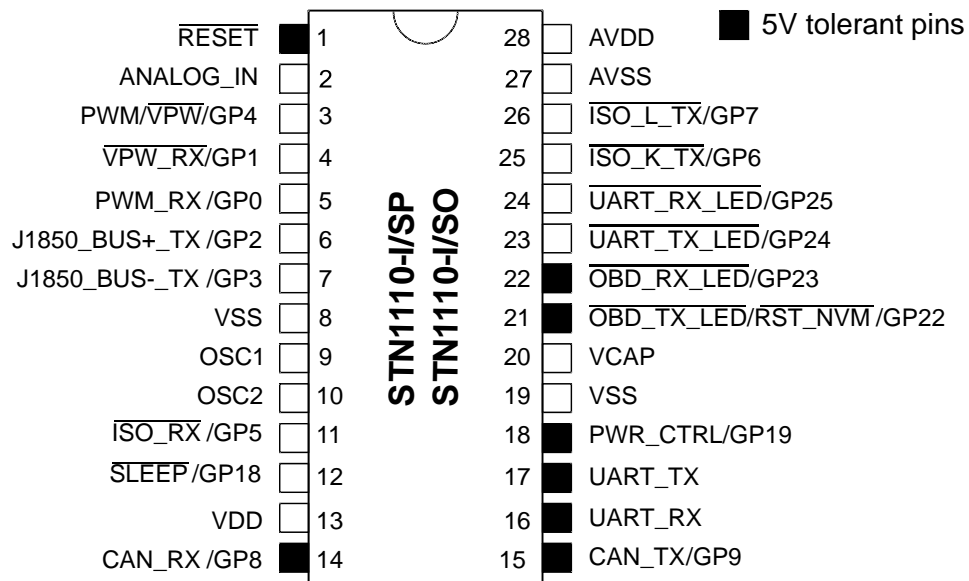

28-Pin QFN-S⁽¹⁾

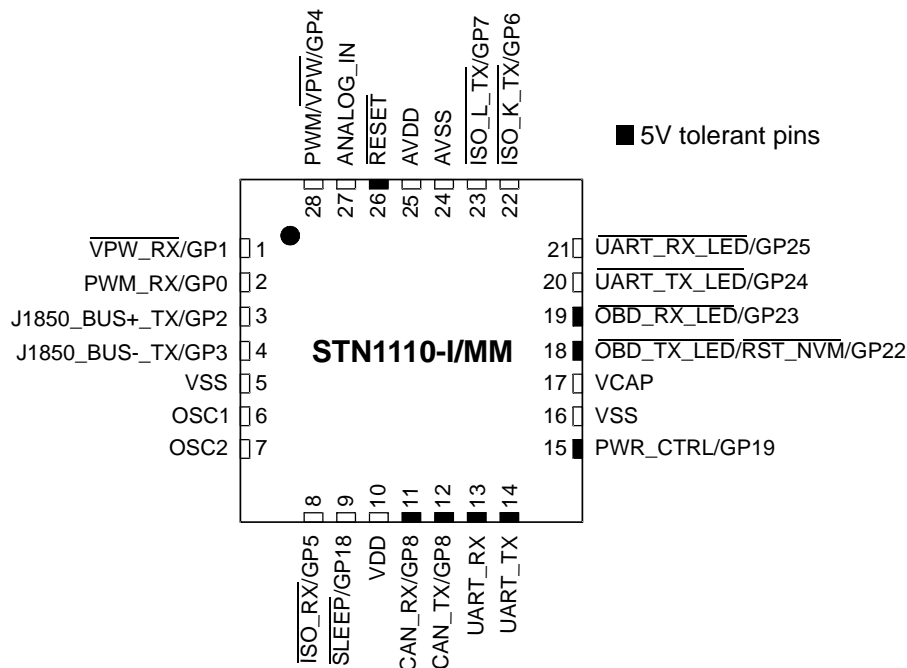

Note 1. The metal plane at the bottom of the device is not connected to any pins and is recommended to be connected to VSS externally.

4.1 Pinout Summary

Table 1: Pinout Summary

Pin Number		Pin Name	Pin Type	Pin Description
SOIC SPDIP	QFN-S			
1	26	RESET	I, 5V	Active low device reset input
2	27	ANALOG_IN	A	Analog voltage measurement input
3	28	PWM/VPW/GP4	O, 4x	SAE J1850 PWM/VPW Bus+ voltage select output
4	1	VPW_RX/GP1	I	Active low J1850 VPW receive input
5	2	PWM_RX/GP0	I	SAE J1850 PWM receive input
6	3	J1850_BUS+_TX/GP2	O, 4x	SAE J1850 Bus+ transmit output
7	4	J1850_BUS-_TX /GP3	O, 4x	SAE J1850 Bus- transmit output
8	5	Vss	P	Ground reference for logic and I/O pins
9	6	OSC1	I	16.000 MHz oscillator crystal input
10	7	OSC2	O	16.000 MHz oscillator crystal output
11	8	ISO_RX/GP5	I	Active low ISO 9141/ISO 14230 K-line input
12	9	SLEEP/GP18	I	External sleep control input
13	10	VDD	P	Positive supply for logic and I/O pins
14	11	CAN_RX/GP8	I, 5V	CAN receive input
15	12	CAN_TX/GP9	OD, 5V, 4x	CAN transmit output
16	13	UART_RX	I, 5V	UART receive input
17	14	UART_TX	OD, 5V, 4x	UART transmit output
18	15	PWR_CTRL/GP19	OD, 5V, 4x	External power control output
19	16	Vss	P	Ground reference for logic and I/O pins
20	17	VCAP	P	CPU logic filter capacitor connection
21	18	OBD_TX_LED/RST_NVM /GP22	OD/I, 5V, 2x	Active low OBD transmit activity LED output <i>and</i> active low input to reset non-volatile settings to factory defaults
22	19	OBD_RX_LED//GP23	OD, 5V, 2x	Active low OBD receive activity LED
23	20	UART_TX_LED/GP24	O, 4x	Active low UART transmit activity LED output
24	21	UART_RX_LED/GP25	O, 4x	Active low UART transmit activity LED output
25	22	ISO_K_TX/GP6	O, 4x	Active low ISO 9141/ISO 14230 K-line output
26	23	ISO_L_TX/GP7	O, 4x	Active low ISO 9141/ISO 14230 L-line output
27	24	AVss	P	Analog ground reference
28	25	AVDD	P	Analog positive supply
—	PAD		—	Thermal pad

Legend: I – Schmitt trigger input with CMOS levels O – digital output 2x – 2x source/sink driver
A – analog input OD – open drain output 4x – 4x source/sink driver
P – power pin 5V – 5 volt tolerant pin

Note 1: Excessive continuous power cycling may cause failure of the IC. See Section 5.9 "Power and Sleep Considerations"

4.2 Detailed Pin Descriptions

RESET

Device reset input. A logic low pulse (min 2 μ s) on this pin will reset the device. Apply a continuous logic low to hold the device in reset. If your circuit does not use this functionality, connect this pin to VDD.

ANALOG_IN

Analog voltage measurement input (AVDD max). By default, this input is calibrated for an external 62 k Ω /10 k Ω voltage divider connected to battery positive. Connect to AVSS if unused.

PWM / VPW

The firmware uses this pin to control the voltage level of the SAE J1850 PWM/VPW Bus+ supply. When the PWM protocol is selected, it outputs a logic high to switch the supply voltage to a nominal 5V. When the VPW protocol is selected, it outputs a logic low to switch the supply voltage to a nominal 8V. This pin has a 4x current rating (see Table 6 “Output Pin DC Specifications”). Leave unconnected if unused.

VPW_RX

Active low SAE J1850 VPW receive input. When the SAE J1850 Bus+ is in the recessive (low) state, this pin should be at a logic high level. When the SAE J1850 Bus+ is in the dominant (high) state, this pin should be at a logic low level. Pull up to VDD if unused.

PWM_RX

SAE J1850 PWM receive input. When the SAE J1850 bus is in the recessive state (Bus+ is low, Bus- is high), this pin should be at a logic low level. When the SAE J1850 bus is in the dominant (Bus+ is high) state, this pin should be at a logic high level. Connect to VSS if unused.

J1850_BUS+_TX

SAE J1850 Bus+ transmit output. When the pin is high, Bus+ should be high (dominant). This pin has a 4x current rating (see Table 6 “Output Pin DC Specifications”). Leave unconnected if unused.

J1850_BUS-_TX

SAE J1850 Bus- transmit output. When the pin is high, Bus- should be low (dominant). This pin has a 4x current rating (see Table 6 “Output Pin DC Specifications”). Leave unconnected if unused.

Vss

Ground reference for logic and I/O pins.

OSC1, OSC2

16.000 MHz oscillator crystal connection.

ISO_RX

Active low ISO 9141/ISO 14230 K-line receive input. When K-line is high (recessive), this pin should be at a logic low level. Connect to VSS if unused.

SLEEP

External sleep control input. When enabled in firmware, puts the device into low-power sleep mode. Polarity of this pin can be configured in firmware; default configuration is active low. Internal pull-up to VDD is enabled by default, but can be disabled in firmware. Leave unconnected if unused.

VDD

Positive 3.0 – 3.6V supply for logic and I/O pins.

CAN_RX

CAN receive input. Compatible with 3.3V and 5V logic. Pull up to VDD if unused.

CAN_TX

CAN transmit output. Open drain – requires a pull-up to VDD or 5V. This pin has a 4x current rating (see Table 6 “Output Pin DC Specifications”). Pull-up value depends on CAN baud rates used and the trace length (higher resistor values can be used with lower baud rates and shorter traces); recommended value is 1 k Ω . Pull up to VDD via 100 k Ω resistor if unused.

UART_RX

UART receive input. Compatible with 3.3V and 5V logic.

UART_TX

UART transmit output. Open drain – requires a pull-up to VDD or 5V. This pin has a 4x current rating (see Table 6 “Output Pin DC Specifications”). Pull-up value depends on UART baud rate and the trace length (higher resistor values can be used with lower baud rates and shorter traces); typical value is 1 k Ω .

PWR_CTRL

External power control output. Used to switch external circuitry into low-power (sleep) state. Polarity can be configured in firmware; default configuration is active high (logic low = sleep mode). Open drain – requires a pull-up to VDD or 5V; be mindful of the fact that the pull-up will draw current in low-power state. This pin has a 4x current rating (see Table 6 “Output Pin DC Specifications”). Pull down to VSS via 100 k Ω resistor if unused.

VCAP

CPU logic filter capacitor connection. Connect to a low-ESR (< 5 Ω) tantalum or ceramic capacitor. Minimum value is 4.7 μ F; typical value is 10 μ F.

OBD_TX_LED / RST_NVM

Active low OBD transmit activity LED output *and* active low input to reset NVM to factory defaults. Open drain – requires a pull-up to VDD or 5V. This pin has a 2x current rating (see Table 6 “Output Pin DC Specifications”). Pull up to VDD via 100 k Ω resistor if unused.

OBD_RX_LED

Active low OBD receive activity LED. Open drain – requires a pull-up to VDD or 5V when configured as interrupt. This pin has a 2x current rating (see Table 6 “Output Pin DC Specifications”). Pull up to VDD if unused.

UART_TX_LED

Active low UART transmit activity LED output. Voltage on the anode of the LED must not exceed VDD + 0.3V. This pin has a 4x current rating (see Table 6 “Output Pin DC Specifications”). Leave unconnected if unused.

UART_RX_LED

Active low UART transmit activity LED output. Voltage on the anode of the LED must not exceed VDD + 0.3V. This pin has a 4x current rating (see Table 6 “Output Pin DC Specifications”). Leave unconnected if unused.

ISO_K_TX

Active low ISO 9141/ISO 14230 K-line output. When the pin is logic high, K-line should be low. This pin has a 4x current rating (see Table 6 “Output Pin DC Specifications”). Leave unconnected if unused.

ISO_L_TX

Active low ISO 9141/ISO 14230 L-line output. When the pin is logic high, L-line should be low. This pin has a 4x current rating (see Table 6 “Output Pin DC Specifications”). Leave unconnected if unused.

AVSS

Analog ground reference. Must be connected to analog “clean” ground (between VSS - 0.3V and VSS + 0.3V) or VSS.

AVDD

Analog positive supply. Must be connected to VDD or an external voltage reference (between VDD - 0.3V or 3.0V, whichever is greater and VDD + 0.3V or 3.6V, whichever is less). AVDD may be decoupled from digital supply by connecting it to VDD via a 10 Ω resistor or a small (10 μ H – 47 μ H) inductor.

GPxx

Pins labeled with GPxx can be reassigned for general purpose input/output (GPIO) pins. All GPIO pins are multiplexed and share the physical pin with other functions (e.g., OBD transceivers, LEDs). The name of the pin defines the priority of each function associated with the pin. Attempting to control GPIO pins when the default multiplexed functionality is not disabled can lead to unpredictable behavior. For example, before UART_TX_LED/GP24 pin can be used as GPIO, LEDs must be disabled (see STUIL command description in OBDLink® FRPM). Consult individual pin descriptions for instructions on what to do when the pin is unused.

PAD

The metal plane at the bottom of the device (QFN package only). It is not connected to any pins internally. Connect to VSS externally.

5.0 Guidelines for Getting Started with STN1110

5.1 Basic Connection Requirements

Getting started with the STN1110 IC requires attention to a minimal set of device pin connections before proceeding with development. The following is a list of pin names, which must always be connected:

- **VDD and VSS** pins (see Section 5.2 “Decoupling Capacitors”)
- **AVDD and AVSS** pins (see Section 5.2 “Decoupling Capacitors” and Section 5.4 “AVDD and AVSS Pins”)
- **VCAP** (see Section 5.5 “Internal Voltage Regulator Filter Capacitor”)
- **OSC1 and OSC2** pins (see Section 5.6 “Oscillator Pins”)
- **RESET** pin (see Section 5.7 “Device Reset Pin”)
- **RST_NVM** pin (see Section 5.8 “NVM Reset Input”)
- **Open Drain Output Pull-ups** (see 5.10 “Open Drain Outputs”)

5.2 Decoupling Capacitors

The use of decoupling capacitors on every pair of power supply pins, such as VDD, VSS and AVDD, AVSS is required. Consider the following criteria when using decoupling capacitors:

- **Value and type of capacitor:** Recommendation of 1 μF , 10-20V. This capacitor should be a low-ESR and have resonance frequency in the range of 20 MHz and higher. It is recommended that ceramic capacitors be used.
- **Placement on the printed circuit board:** The decoupling capacitors should be placed as close to the pins as possible. It is recommended to place the capacitors on the same side of the board as the device. If space is constricted, the capacitor can be placed on another layer on the PCB using a via; however, ensure that the trace length from the pin to the capacitor is within $\frac{1}{4}$ ” (6 mm) in length.
- **Handling high frequency noise:** If the board is experiencing high frequency noise, upward of tens of MHz, add a second ceramic-type capacitor in parallel to the above described decoupling capacitor. The value of the second capacitor can be in the range of 0.01 μF to 0.001 μF . Place this second capacitor next to the primary decoupling capacitor.

- **Maximizing performance:** On the board layout from the power supply circuit, run the power and return traces to the decoupling capacitors first, and then to the device pins. This ensures that the decoupling capacitors are first in the power chain. Equally important is to keep the trace length between the capacitor and the power pins to a minimum thereby reducing PCB track inductance.

5.3 Tank Capacitors

On boards with power traces running longer than six inches in length, use a tank capacitor for integrated circuits, including STN1110, to supply a local power source. The value of the tank capacitor should be determined based on the trace resistance that connects the power supply source to the device, and the maximum current drawn by the device in the application. In other words, select the tank capacitor so that it meets the acceptable voltage sag at the device. Typical values range from 4.7 μF to 47 μF .

5.4 AVDD and AVSS Pins

As a minimum, AVDD must be connected directly to VDD and AVSS must be connected directly to VSS. It is recommended that AVDD be connected to VDD via a 10 Ω resistor or a small (10 μH – 47 μH) inductor.

AVSS should be connected to the electrically cleanest ground net (plane). For best results, analog circuitry should have a separate ground plane with a point connection to VSS ground plane as close as possible to the AVSS pin.

5.5 Internal Voltage Regulator Filter Capacitor

A low-ESR ($< 5 \Omega$) capacitor is required on the VCAP pin, which is used to stabilize the internal voltage regulator output voltage. The VCAP pin must not be connected to VDD, and must have a capacitor between 4.7 μF and 10 μF , 16V connected to ground. The type can be ceramic or tantalum. Refer to Section 7.2 “Electrical Characteristics” for additional information. The placement of this capacitor should be close to the VCAP pin. It is recommended that the trace length not exceed $\frac{1}{4}$ ” (6 mm).

5.6 Oscillator Pins

The oscillator circuit should be placed on the same side of the board as the device. Also, place the oscillator circuit close to the oscillator pins, not

exceeding one-half inch (12 mm) distance between them. The load capacitors should be placed next to the oscillator itself, on the same side of the board. Use a grounded copper pour around the oscillator circuit to isolate them from surrounding circuits. The grounded copper pour should be routed directly to the STN1110 ground. Do not run any signal traces or power traces inside the ground pour. Also, if using a two-sided board, avoid any traces on the other side of the board where the crystal is placed.

5.7 Device Reset Pin

RESET pin must be logic high for STN1110 to run. If this pin is not controlled by the host controller, it must be connected to VDD.

It is recommended to pull up RESET pin to VDD via a 10 kΩ resistor.

5.8 NVM Reset Input

All programmable parameters will be turned off and reset to their default values by holding RST_NVM input low for 5 seconds. After RST_NVM input is released, device will set all factory defaults, and then perform an ATZ reset.

RST_NVM pin must be pulled up to VDD via a 100 kΩ resistor for proper device operation.

5.9 Power and Sleep Considerations

While it is possible to disconnect the VDD/AVDD pins from the power source to reduce power consumption, we recommend using the PowerSave functionality instead (see the STN11xx Family Reference and Programming Manual).

Be warned that continuous power cycling may cause failure of the IC. In lab testing and at least one customer application, turning the power on and off in excess of approximately 400,000 times led to memory corruption.

5.10 Open Drain Outputs

All open drain outputs (as specified in section 4.1) that are in use must be pulled up to VDD or 5V. Specifically, UART_TX pin must be pulled up in order to be able to communicate with the device. See section 4.2 “Detailed Pin Descriptions” for more information.

5.11 Unused Inputs and Unused Open Drain Outputs

None of the unused inputs or unused open drain outputs (as specified in section 4.1) should be left unconnected. The STN1110 is a CMOS integrated circuit. Leaving any of its inputs or open drain outputs floating may result in IC damage.

Unused open drain outputs can only be terminated with a resistor connected to VDD or 5V. Unused inputs can be terminated via a resistor or direct connection to VSS or VDD.

Unused inputs and open drain outputs should be connected as shown in Table 2. See section 4.2 “Detailed Pin Descriptions” and section 6.1 “Recommended Minimum Connection” for more information.

Table 2 – Recommended Unused Input and Open Drain Output Connections

Pin Number		Pin Name	Level
SOIC SPDIP	QFN-S		
1	26	RESET	H
2	27	ANALOG_IN	L ⁽¹⁾
4	1	VPW_RX	H ⁽¹⁾
5	2	PWM_RX	L ⁽¹⁾
11	8	ISO_RX	L ⁽¹⁾
12	9	SLEEP	— ⁽²⁾
14	11	CAN_RX	H
15	12	CAN_TX	H ⁽³⁾
16	13	UART_RX	H
17	14	UART_TX	H ⁽³⁾
18	15	PWR_CTRL	L ⁽⁴⁾
21	18	OBD_TX_LED /RST_NVM	H ⁽³⁾
22	19	OBD_RX_LED	H ⁽³⁾

- Note**
1. These inputs may be connected to either VDD or VSS. However, the preferred level is shown.
 2. SLEEP input has internal pull-up to VDD enabled by default. Therefore, it can be left unconnected.
 3. These open drain outputs cannot be connected to VDD directly. They can only be connected to VDD or 5V via a resistor.
 4. This open drain output should not be connected to VSS directly. For reduced current consumption during sleep, when unused, this output should be connected to VSS via a resistor.

6.0 Reference Schematics

6.1 Recommended Minimum Connection

Figure 1 – Recommended Minimum Connection shows the recommended minimum of components necessary to get the STN1110 to operate reliably, while minimizing power consumption.

This is not a practical circuit; it is intended as a reference to show what to do with any unused pins. Refer to the detailed pin descriptions (Section 4.2) for more information.

Figure 1 – Recommended Minimum Connection

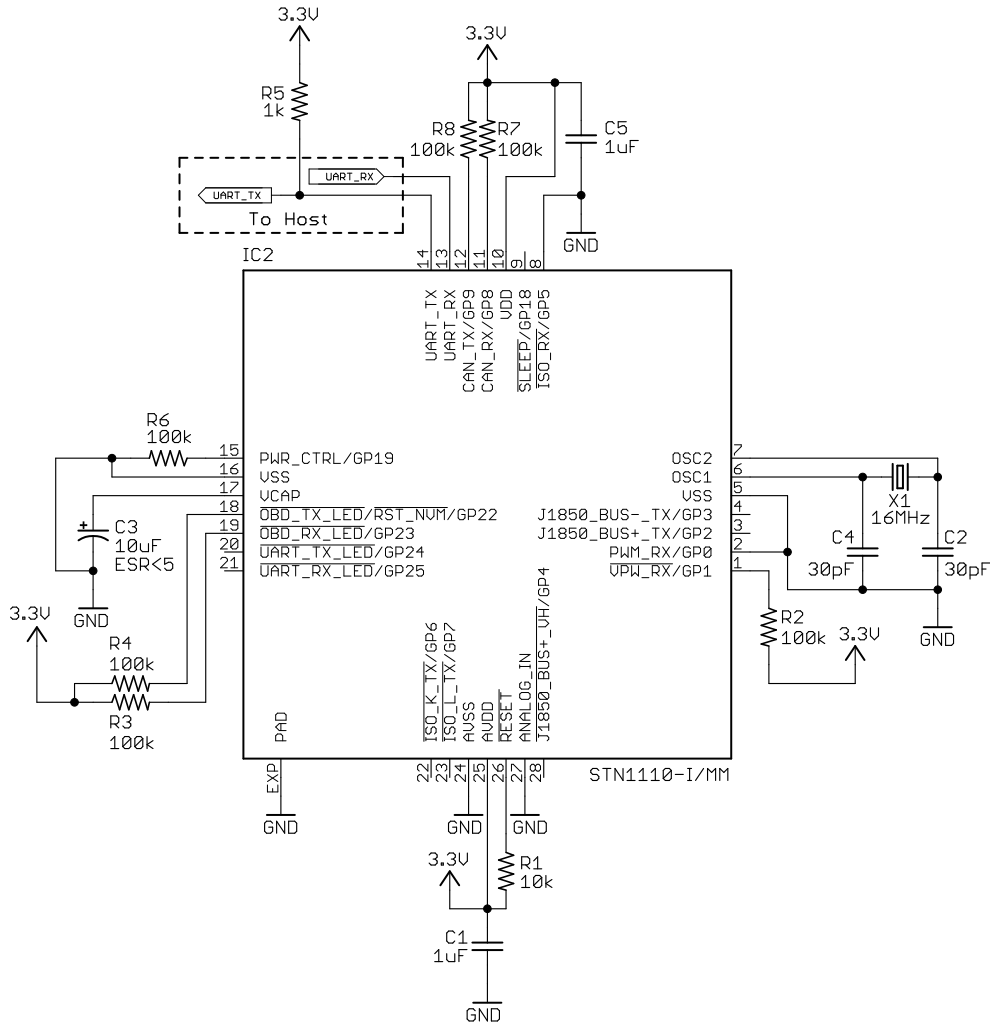

6.2 Typical Configuration

This section contains schematics showing the typical configuration for the various circuit blocks. In this revision, the circuit blocks have been designed to meet the requirements of a “permanently attached device” scenario: low power consumption in sleep, and protection against interference with the OBD bus.

Pay special attention when choosing substitutes for components with specific part numbers, to make sure they have the same or better characteristics. Components without specific part numbers are generic. Use good engineering practices and common sense to make sure the specific parts you choose are appropriate for your application.

6.2.1 STN1110 IC

Figure 2 shows the circuit block for the STN1110 IC, including:

- **Pull-up resistors** (see Section 4.2 for more information)

- **Decoupling capacitors** (Section 5.2)
- **VCAP** (Section 5.5)
- **Crystal oscillator** (Section 5.6)
- **RESET pin** (Section 5.7)
- **RST_NVM pin** (Section 5.8)

Figure 2 – STN1110 IC

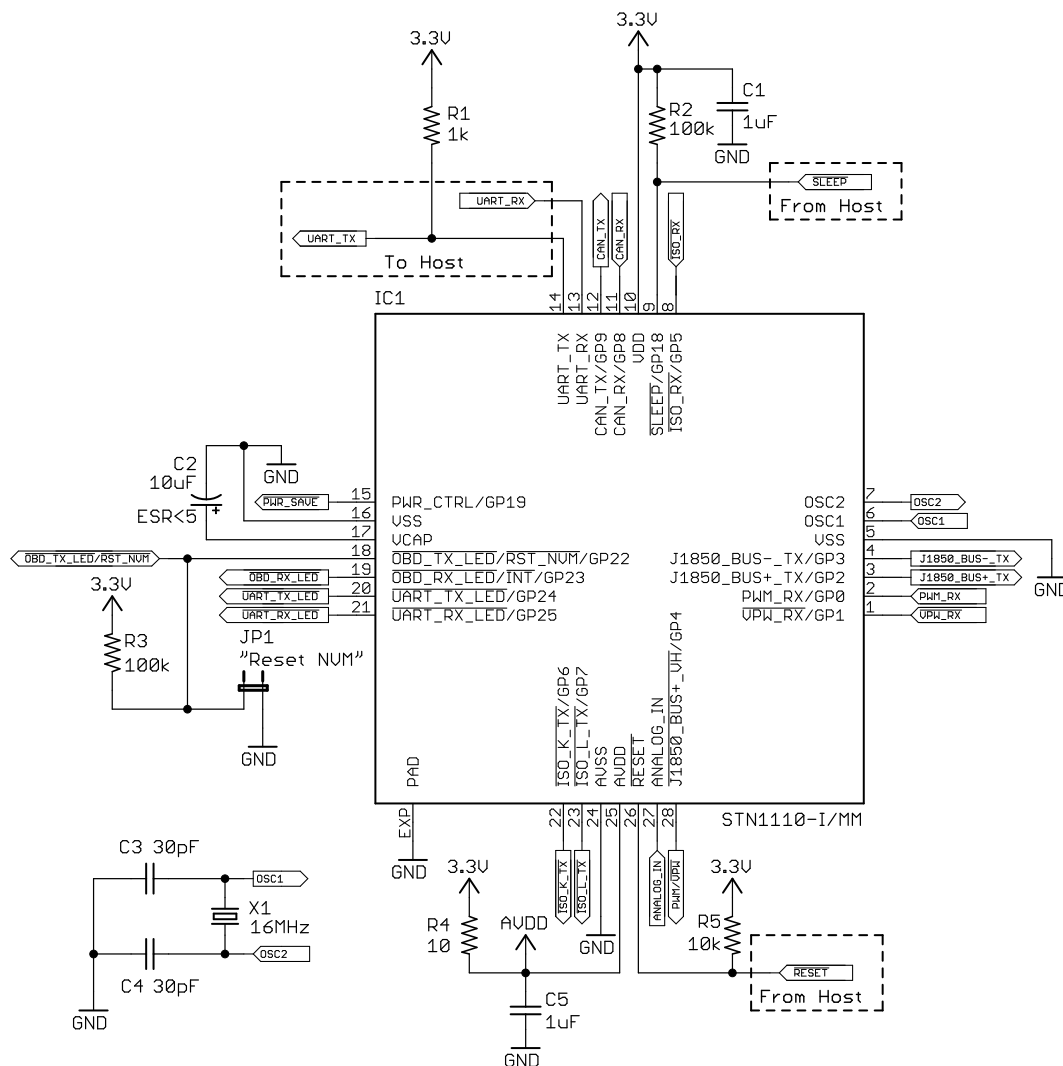

Be sure to pull up RST_NVM pin to VDD or 5V via a 100 kΩ resistor, whether an LED is connected or not. Failure to do so may result in mysterious and unpredictable device resets.

Another common mistake is to use the load capacitance (C_L) value specified by the crystal manufacturer as the capacitance for C3 and C4. This results in marginal oscillator performance, and creates a potentially insidious problem that may not get discovered until after the design enters production: the circuit may work fine in the lab, but would fail to start up in the field under certain conditions.

To avoid this, use the following formula to calculate the value of the loading capacitors:

$$C3 = C4 = (C_L - C_{stray}) \times 2$$

C_{stray} consists of: pin capacitance; capacitor, resistor, and crystal or resonator lead capacitance; and board or trace related capacitance. For the typical surface-mount design, use $C_{stray} = 3pF$.

Avoid using crystals with $C_L < 15pF$.

For more information, see Microchip Technology app notes AN826 and AN849.

6.2.2 Voltage Sense

For best results, connect the voltage sense circuit directly to pin 16 of the OBD port (marked as DLC_RAW in the circuit examples), bypassing the overvoltage/reverse polarity and power conditioning circuitry.

D1, D3, R6, and the internal diode provide adequate protection of the ANALOG_IN pin against overvoltage and reverse polarity conditions.

If you choose to connect ANALOG_IN after the protection/filter circuit, expect a loss of accuracy and reduced sensitivity of the “wake-up on voltage change” (STSLVG) trigger in sleep. Use the offset parameter of the STVCAL command to compensate for the voltage drop across any series components (e.g., reverse polarity protection diode).

Figure 3 – Voltage Sense

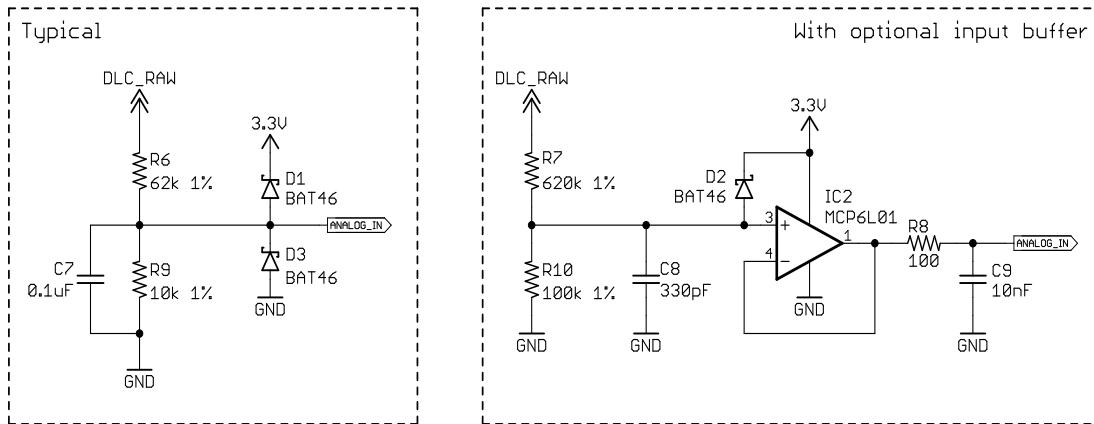

6.2.3 LEDs

Even if your design does not use LEDs as part of the user interface, consider including them in your prototype as a troubleshooting aid.

Limiting resistor values are for reference only, actual values depend on the LEDs used.

Tip: use potentiometers to adjust the brightness and make it consistent across the LEDs, then measure the resistance to select fixed resistors of appropriate size.

Figure 4 – LEDs

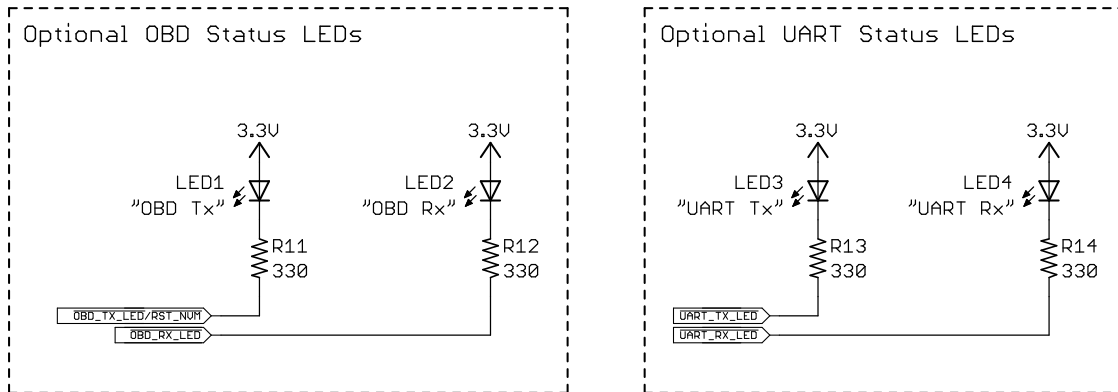

6.2.4 OBD Port Connector and ESD protection

Take care to provide sufficient spacing between power (pins 16, 4, & 5) and signal pins. Note that in the example schematic, pins 4 & 5 (Chassis & Signal grounds) are connected together. This is done

because on a small number of vehicle models, either pin can be missing.

Place ESD protection as close as possible to the OBD port pins.

Figure 5 – OBD Port Connector and ESD Protection

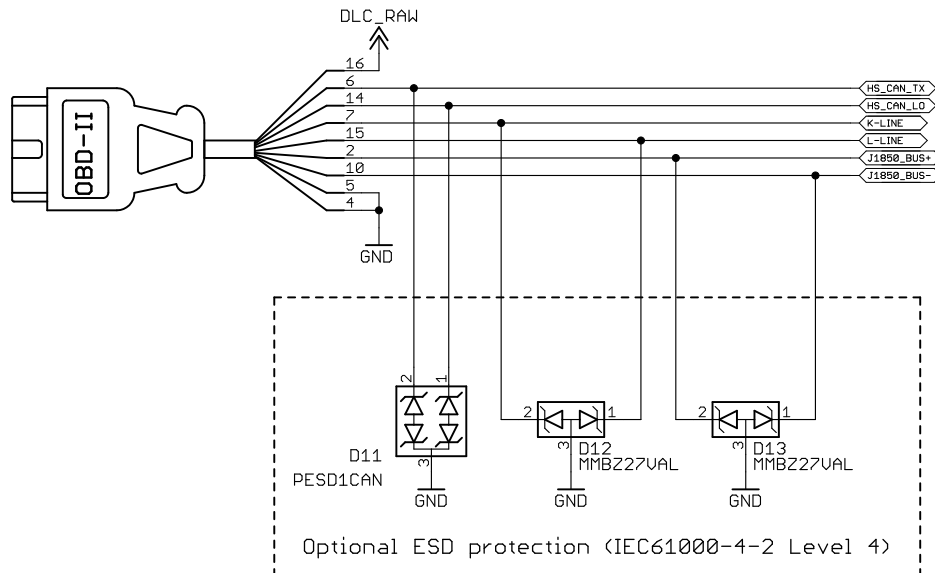

6.2.5 Overvoltage Protection Circuit

It is critically important to protect devices attached to the OBD port from voltage spikes. ISO 7637-2 describes several types of high-voltage transients, the most dangerous of which is the Pulse 5A/B (“load dump”), a high-energy pulse with voltage as high as 60V.

In this section, we present two options for overvoltage protection (OVP): PTC/TVS and transistor-based.

Figure 6 – Option 1: PTC/TVS Overvoltage Protection

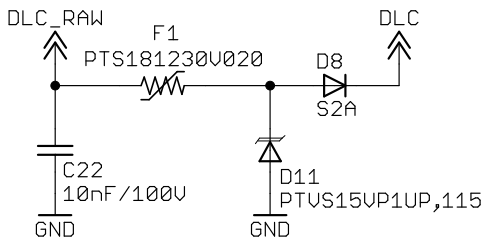

$I_{max} = 200mA$

PTC/TVS-based OVP (Figure 6) is the simpler of the two designs, with a lower part count. In addition, this circuit may allow the load to remain powered during an overvoltage event, which may be an advantage in some situations. However, it tends to be bulkier and more expensive, especially for voltages above 60V (e.g., load dump on 24V systems) and higher operating currents.

This circuit relies on the “shunt” action of the TVS (“transient voltage suppressor”, similar to a Zener diode) which trips the PTC (“resettable fuse”).

When the DLC_RAW voltage exceeds the breakdown voltage of the TVS (D11), its resistance drops rapidly, providing a low impedance path for the transient current. This causes the current through the PTC (F1) to increase, causing the PTC to change from low to high resistance and interrupt the current flow.

It is important to correctly match the PTC and TVS. Select a PTC with a trip current that is above the maximum normal operating current, then select a TVS with a trip current rating that is sufficient to reliably trip the PTC.

One inherent flaw of the PTC/TVS-based OVP is the existence of a “gray band” just above the breakdown voltage (V_{BR}) of the TVS where the circuit does not work as intended. The voltage inside this band is insufficient for the TVS to fully enter avalanche mode; as a result, the current through the TVS is lower than is necessary to trip the PTC, and can result in TVS damage from overheating. You should take care to select the TVS such that the circuit is not subjected to the voltages inside the “gray band” for longer than a few milliseconds.

The purpose of the small capacitor (C22) on the input of this OVP circuit is to help suppress fast transients. Note that the reverse polarity protection diode D8 is connected *after* the PTC/TVS, to avoid subjecting it to the high clamping currents during the overvoltage condition.

Figure 7 – Option 2: Transistor Based Overvoltage Protection

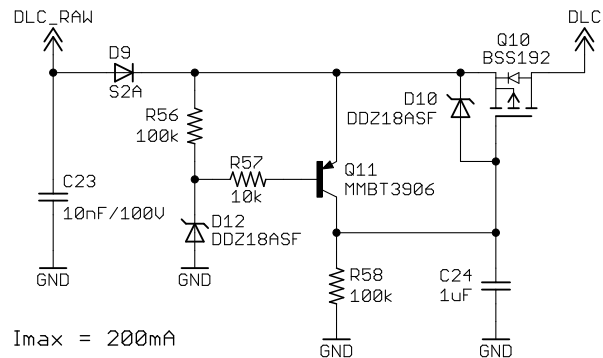

$I_{max} = 200mA$

Transistor-based OVP (Figure 7) has a higher part count, but can be physically smaller and less expensive than the PTC/TVS design.

This circuit relies on a small Zener diode to detect an overvoltage condition, and a series P-FET (Q10) to disconnect the load.

When the DLC_RAW voltage exceeds the breakdown voltage of D12, the Zener diode begins to avalanche, turning on Q11 and turning off Q10.

The circuit can remain in the overvoltage condition indefinitely.

R57 provides current limiting for Q11, R58 is a pull-down for Q10 (keeping it on during normal operation), and D10 is protecting the gate of Q10.

6.2.8 ISO 9141/ISO 14230 Transceiver

The ISO 9141/ISO 14230 transceiver consists of the K/L line transmitter (Q3, Q4) and a K-line receiver based on the LM339 comparator (IC5A).

Note that for proper operation, the LM339 *must* be powered from DLC_SW (not a lower voltage power source).

Also note that there are two transistors (Q1 and Q2) used to turn off the pull ups in power save mode. A common mistake is to not use a switch for DLC, and instead connect the transmitter pull-ups R27 and R28 directly to DLC or DLC_SW. Doing so can have negative consequences, ranging from excessive current draw in sleep to interference with the in-vehicle network communication resulting in an engine stall.

Figure 10 – ISO 9141/ISO 14230 Transceiver

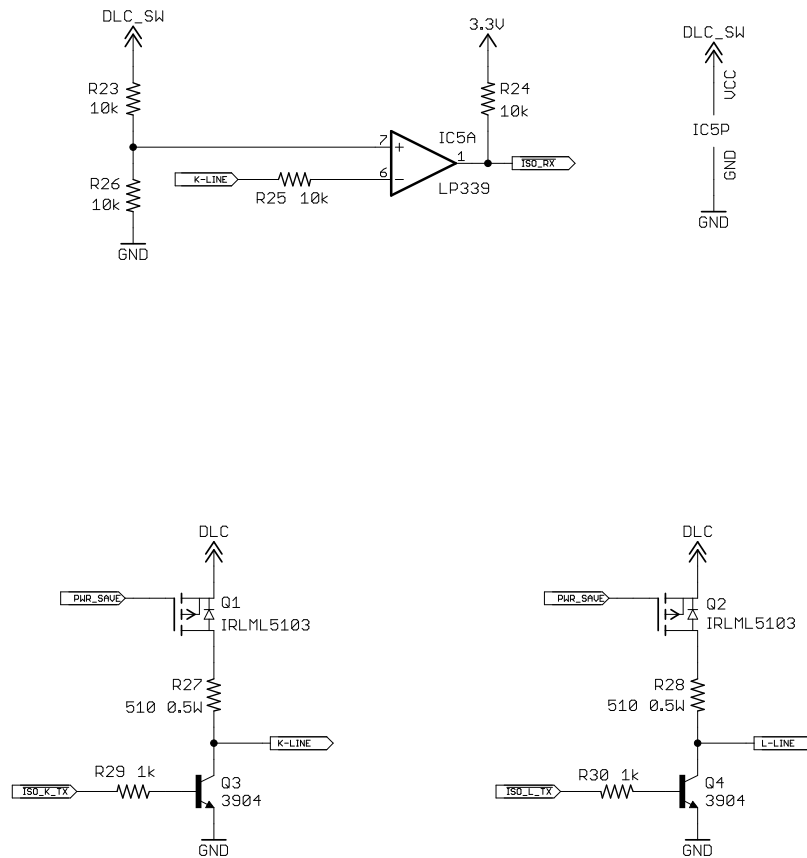

6.2.9 High-Speed CAN Transceiver

The High-Speed CAN transceiver shown in Figure 11 is part of the “generic” OBD-II standard. We chose the MCP2562 for this reference circuit, for two reasons: it has very low standby current, and is available in a small 3x3 DFN package.

The low standby current means that the transceiver does not need to be switched off in low power mode. Instead, the STN1110 can put the transceiver in low power mode by applying a logic “high” to the STBY pin. In this mode, the transmitter and the high-speed part of the receiver are switched

off, but the low-power receiver and the wake-up filter block are enabled to allow the device to wake-up on CAN bus activity.

The only additional components are the decoupling capacitor C10, and the EMI filters R14/C11 and R15/C12.

A common mistake is to add bus termination to the CAN drivers; it is unnecessary, and even harmful, because it lowers the impedance of an already terminated vehicle CAN bus.

Figure 11 – High Speed CAN Transceiver

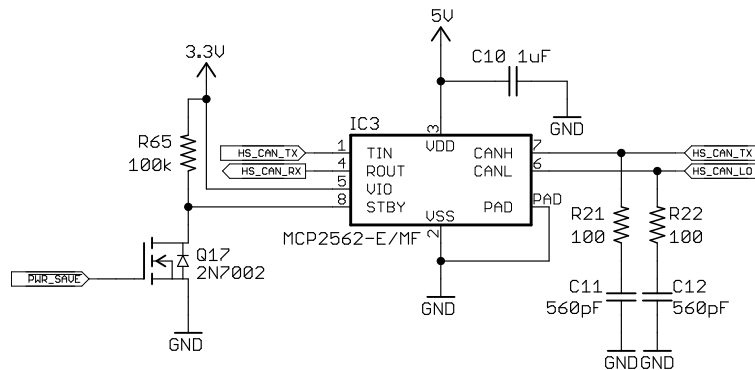

6.2.10 Alternative (MCP2551) HS-CAN Transceiver

The MCP2551 is an older generation CAN transceiver which is sometimes used in new designs for cost reasons. Due to its high sleep current (up to 465 µA) it should be switched off in sleep. For this reason, the MCP2551 is powered from 5V_SW.

The R17 and R18 pull-ups to 3.3V on TIN and ROUT are necessary to keep the signal lines from floating in sleep mode.

The 1k pull-up to 5V_SW on the TIN pin (R16) is required for normal operation. It is switched off in sleep mode to reduce the current consumption.

R21 is used for slope control; the value of 4.7kΩ was selected to reduce EMI without compromising the reliability of communication. Do not increase it further.

Figure 12 – MCP2551 CAN Transceiver

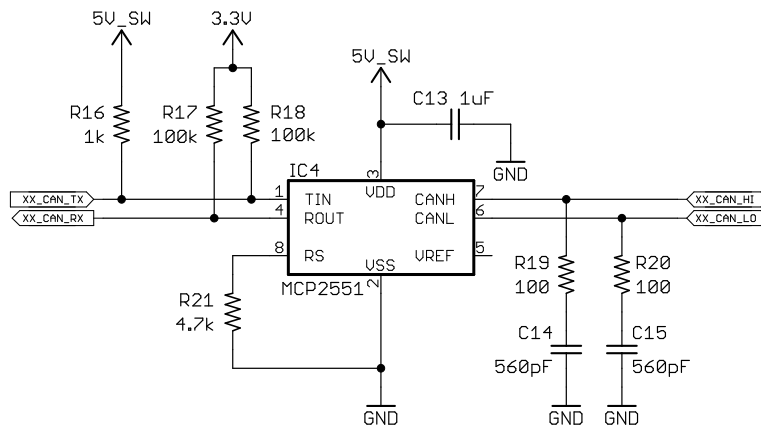

6.2.11 SAE J1850 Transceiver

The SAE 1850 transceiver is made up of five blocks: V_J1850 power supply, J1850 BUS+ transmitter, J1850 BUS- transmitter, PWM receiver, and VPW receiver.

The V_J1850 power supply is used to power the J1850 BUS+ transmitter, which is used by both PWM and VPW protocols. PWM and VPW require different voltages, approximately 5V and 7V, respectively. STN1110 sets the voltage by controlling the LM317 adjustable regulator via the PWM/VPW signal. A logic-LOW on the PWM/VPW input causes the LM317 to output a voltage slightly higher than 7V (to account for the voltage drop in the J1850 BUS+

transmitter) while a logic-HIGH turns on Q5 which shunts R36, reducing the voltage to slightly higher than 5V. The power supply is powered from DLC_SW, and is powered off in sleep.

The J1850 BUS+ transmitter consists of the R43 bus pull-down, and a two-stage transistor switch Q6/Q7. Schottky diodes D4 and D5 prevent current backflow from/into the J1850_BUS+ line.

The J1850 BUS- transmitter can be implemented using either an NPN bipolar transistor, or an n-channel MOSFET. The NPN version is less sensitive to ESD.

Figure 13 – SAE J1850 VPW/PWM Transceiver

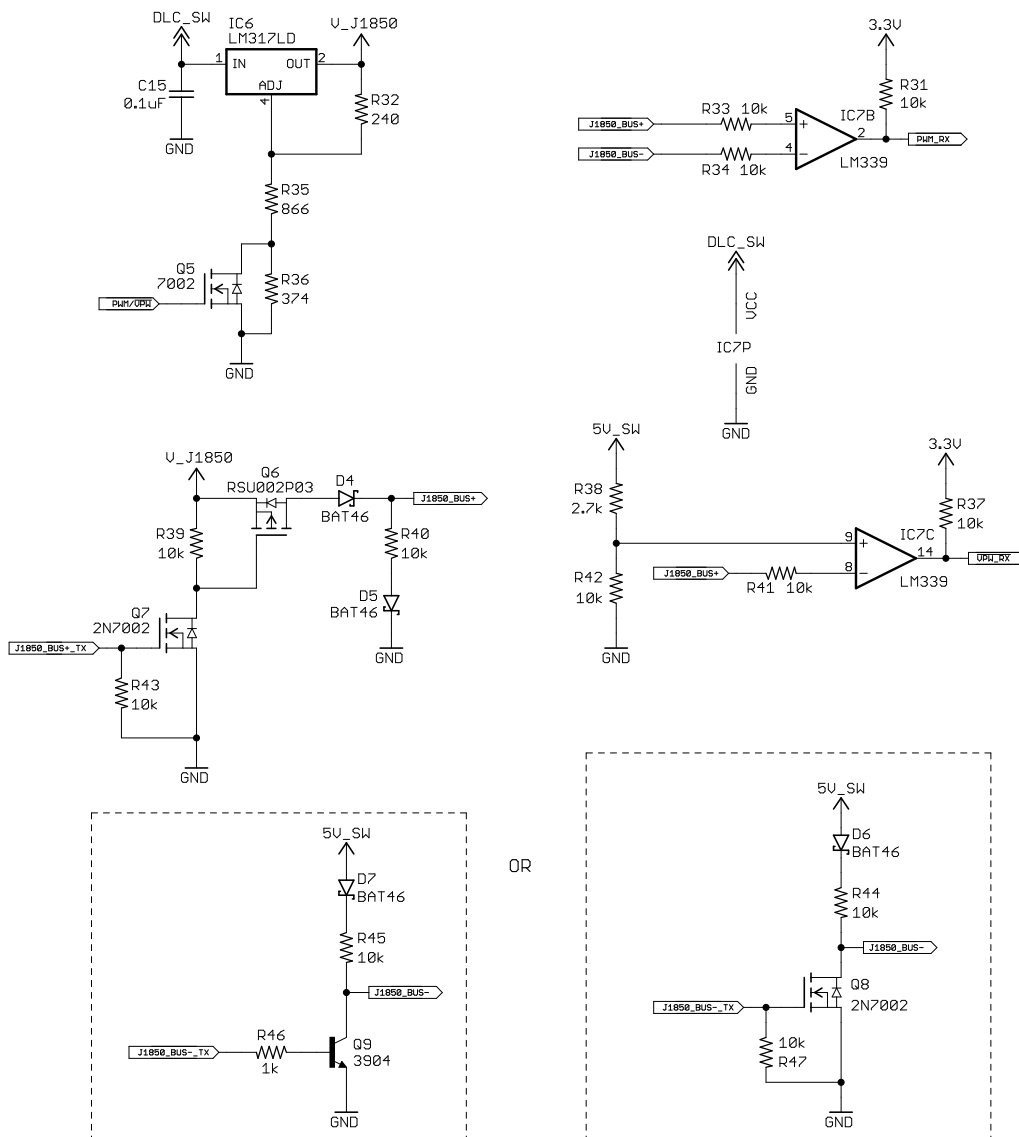

Both the PWM and VPW receivers are based on the LM339 comparator, and are powered from DLC_SW, which means they are powered off in sleep mode.

The PWM receiver is connected to the differential J1850_BUS+/J1850_BUS- lines via 10k Ω resistors.

The VPW receiver uses a voltage divider (R38/R42) to set up the input high/low threshold.

7.0 Electrical Characteristics

This section provides an overview of STN1110 electrical characteristics. Additional information will be provided in future revisions of this document as it becomes available.

The STN1110 is based on the PIC24HJ128GP502 device from Microchip Technology. For more detailed device specifications or clarification, refer to Microchip documentation, available at <http://www.microchip.com>.

7.1 Absolute Maximum Ratings ⁽¹⁾

Ambient temperature under bias	-40°C to +125°C
Storage temperature	-65°C to +160°C
Voltage on VDD with respect to VSS	-0.3V to +4.0V
Voltage on any pin that is not 5V tolerant with respect to VSS⁽²⁾	-0.3V to (VDD + 0.3V)
Voltage on any 5V tolerant pin with respect to VSS when VDD ≥ 3.0V⁽²⁾	-0.3V to +5.6V
Voltage on any 5V tolerant pin with respect to VSS when VDD < 3.0V⁽²⁾	-0.3V to 3.6V
Maximum current sourced/sunk by any 2x output⁽³⁾	8 mA
Maximum current sourced/sunk by any 4x output⁽³⁾	15 mA

- Note**
1. Stresses beyond those listed here can cause permanent damage to the device. These are stress ratings only, and functional operation of the device at those or any other conditions above those indicated in the operation listings of this specification is not implied. Exposure to maximum rating conditions for extended periods can affect device reliability.
 2. See section 4.0 “Pinout” for the list of 5V tolerant pins.
 3. See section 4.1 “Pinout Summary” to determine current rating of individual pins.

7.2 Electrical Characteristics

Table 3: Thermal Operating Conditions

Sym	Characteristic	Min	Typ	Max	Units	Conditions
TJ	Operating Junction Temperature	-40	—	+125	°C	
TA	Operating Ambient Temperature	-40	—	+85	°C	

Table 4: Power Specifications

Sym	Characteristic	Min	Typ ⁽¹⁾	Max	Units	Conditions
VDD	Supply Voltage	3.0	—	3.6	V	
VPOR	VDD Start Voltage to ensure internal power-on reset (POR) signal	—	—	VSS	V	
SVDD	VDD Rise Rate ⁽²⁾ to ensure internal power-on reset (POR) signal	0.03	—	—	V/ms	0–3.0V in 0.1s
AVDD	Analog Supply Voltage	Greater of VDD – 0.3 or 3.0	—	Lesser of VDD + 0.3 or 3.6	V	
AVSS	Analog Ground Reference	VSS – 0.3	—	VSS + 0.3	V	
VBOR	Brown-out Reset Voltage ⁽³⁾ on VDD transition high-to-low	2.40	—	2.55	V	
IDD	Operating Current ⁽⁴⁾	—	68	82 ⁽⁵⁾	mA	

Sym	Characteristic	Min	Typ ⁽¹⁾	Max	Units	Conditions
IPD	Average Sleep Current ^(4,6)	—	98	210 ⁽⁵⁾	μA	T _A = +25°C
		—	300 ⁽⁵⁾	710 ⁽⁵⁾	μA	T _A = +85°C
CEFC	External Filter Capacitor ⁽⁷⁾ connected to VCAP pin	4.7	10	—	μF	ESR < 5 Ω

- Note**
1. Data in Typ column is at 3.3V, 25°C, unless otherwise stated.
 2. This spec must be met in order to ensure that a correct internal power-on reset (POR) occurs. It is easily achieved using most common types of supplies, but may be violated if a supply with slowly varying voltage is used, as may be obtained through direct connection to solar cells or some charge pump circuits.
 3. This parameter is for design guidance only and is not tested in manufacturing.
 4. STN1110 device current only. Does not include any load currents.
 5. Values are characterized, but not tested.
 6. All wakeup triggers are on and wakeup trigger inputs are in their inactive states.
 7. Typical VCAP voltage = 2.5V when VDD ≥ VDDMIN.

Table 5: Input Pin DC Specifications

Sym	Characteristic	Min	Typ ⁽¹⁾	Max	Units	Conditions
VIL	Input Low Voltage					
	MS_CAN_RX pin	VSS	—	0.3 VDD	V	
	all other inputs	VSS	—	0.2 VDD	V	
VIH	Input High Voltage					
	non-5V tolerant pins ⁽²⁾	0.7 VDD	—	VDD	V	
	5V tolerant pins ⁽²⁾	0.7 VDD	—	5.5	V	
VIN	ANALOG_IN Input Voltage	AVSS	—	AVDD	V	
RIN	Recommended ANALOG_IN Voltage Source Impedance	—	—	200	Ω	
IPU	Internal Pull-up Current	50	250	400	μA	VDD = 3.3V, VPIN = VSS
IICL	Input Low Injection Current	0	—	-5 ^(4,7)	mA	All pins, except VDD, VSS, AVDD, AVSS, RESET, VCAP, SLEEP, ISO_RX and ISO_K_TX
IICH	Input High Injection Current	0	—	+5 ^(5,6,7)	mA	All pins, except VDD, VSS, AVDD, AVSS, RESET, VCAP, SLEEP, ISO_RX, ISO_K_TX, and 5V tolerant designated pins
ΣICT	Total Input Injection Current sum of all I/O and control pins	0	—	20 ⁽⁸⁾	mA	Absolute instantaneous sum of all ± input injection currents from all I/O pins (IICL + IICH) ≤ ΣICT

- Note**
1. Data in Typ column is at 3.3V, 25°C, unless otherwise stated.
 2. See section 4.0 “Pinout” for the list of 5V tolerant pins.
 3. Negative current is defined as current sourced by the pin.
 4. VIL source < (VSS – 0.3). Characterized, but not tested.
 5. Non-5V tolerant pins: VIH source > (VDD + 0.3), 5V tolerant pins: VIH source > 5.5V. Characterized, but not tested.
 6. 5V tolerant pins cannot tolerate any “positive” input injection current from input sources > 5.5V.

7. Injection currents > 0 can affect the ADC results by approximately 4-6 counts.
8. Any number and/or combination of inputs listed under IICL or IICH conditions are permitted, provided the mathematical “absolute instantaneous” sum of the input injection currents from all pins does not exceed the specified limit. Characterized, but not tested.

Table 6: Output Pin DC Specifications

Sym	Characteristic	Min	Typ	Max	Units	Conditions
VOL	Output Low Voltage⁽¹⁾ 2x Sink Driver Pins ⁽²⁾	—	—	0.4	V	$I_{OL} \leq 3 \text{ mA}$, $V_{DD} = 3.3\text{V}$
	4x Sink Driver Pins ⁽²⁾	—	—	0.4	V	$I_{OL} \leq 6 \text{ mA}$, $V_{DD} = 3.3\text{V}$
VOH	Output High Voltage⁽¹⁾ 2x Source Driver Pins ⁽²⁾	2.4	—	—	V	$I_{OH} \geq -3 \text{ mA}$, $V_{DD} = 3.3\text{V}$
	4x Source Driver Pins ⁽²⁾	2.4	—	—	V	$I_{OH} \geq -6 \text{ mA}$, $V_{DD} = 3.3\text{V}$
VOH1	Output High Voltage⁽¹⁾ 2x Source Driver Pins ⁽²⁾	1.5	—	—	V	$I_{OH} \geq -6 \text{ mA}$, $V_{DD} = 3.3\text{V}$
		2.0	—	—	V	$I_{OH} \geq -5 \text{ mA}$, $V_{DD} = 3.3\text{V}$
		3.0	—	—	V	$I_{OH} \geq -2 \text{ mA}$, $V_{DD} = 3.3\text{V}$
	4x Source Driver Pins ⁽²⁾	1.5	—	—	V	$I_{OH} \geq -12 \text{ mA}$, $V_{DD} = 3.3\text{V}$
		2.0	—	—	V	$I_{OH} \geq -11 \text{ mA}$, $V_{DD} = 3.3\text{V}$
		3.0	—	—	V	$I_{OH} \geq -3 \text{ mA}$, $V_{DD} = 3.3\text{V}$

- Note**
1. Parameters are characterized, but not tested.
 2. See section 4.1 “Pinout Summary” for the output driver current rating designations.

Table 7: I/O Pin Timing Requirements

Sym	Characteristic	Min	Typ	Max	Units	Conditions
TRST	RESET Pulse Width (low)	2	—	—	μs	
TUWM	Minimum UART Rx Pulse Width required for wakeup (user settable)	—	20	—	ns	user setting < 15
		15	—	65,534	μs	user setting ≥ 15
TSTM	Minimum SLEEP Input Time to stay high before wakeup (user settable)	—	15	—	μs	user setting = 0
		1	—	65,534	ms	user setting > 0

8.0 Packaging Diagrams and Parameters

8.1 SPDIP (SP) Package

28-Lead Skinny Plastic Dual In-Line (SP) – 300 mil Body [SPDIP]

For the most current package drawings, please see the Microchip Packaging Specification located at <http://www.microchip.com/packaging>.

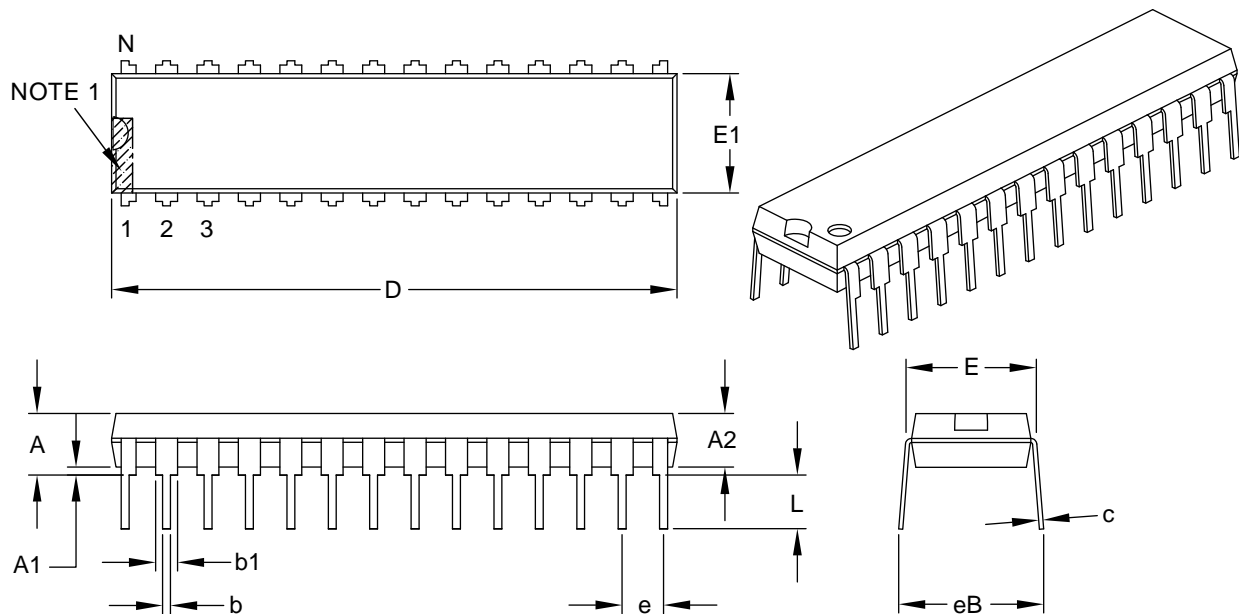

Dimension Limits	Units	INCHES		
		MIN	NOM	MAX
Number of Pins	N	28		
Pitch	e	.100 BSC		
Top to Seating Plane	A	—	—	.200
Molded Package Thickness	A2	.120	.135	.150
Base to Seating Plane	A1	.015	—	—
Shoulder to Shoulder Width	E	.290	.310	.335
Molded Package Width	E1	.240	.285	.295
Overall Length	D	1.345	1.365	1.400
Tip to Seating Plane	L	.110	.130	.150
Lead Thickness	c	.008	.010	.015
Upper Lead Width	b1	.040	.050	.070
Lower Lead Width	b	.014	.018	.022
Overall Row Spacing §	eB	—	—	.430

Notes:

- Pin 1 visual index feature may vary, but must be located within the hatched area.
- § Significant Characteristic.
- Dimensions D and E1 do not include mold flash or protrusions. Mold flash or protrusions shall not exceed .010" per side.
- Dimensioning and tolerancing per ASME Y14.5M.

BSC: Basic Dimension. Theoretically exact value shown without tolerances.

8.2 SOIC 300mil (SO) Package

28-Lead Plastic Small Outline (SO) – Wide, 7.50 mm Body [SOIC]

For the most current package drawings, please see the Microchip Packaging Specification located at <http://www.microchip.com/packaging>.

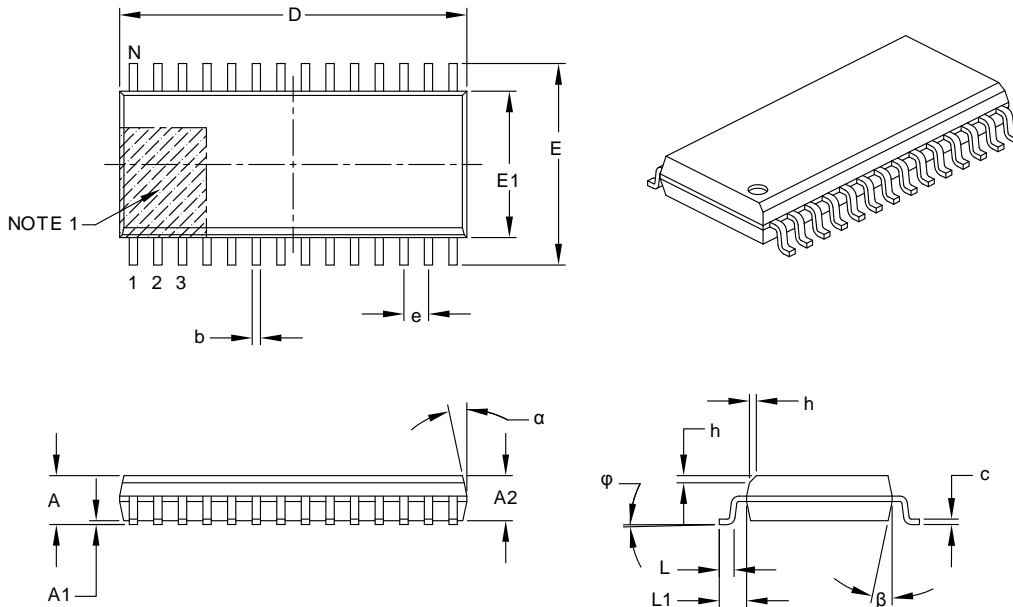

Dimension Limits	Units	MILLIMETERS		
		MIN	NOM	MAX
Number of Pins	N	28		
Pitch	e	1.27 BSC		
Overall Height	A	—	—	2.65
Molded Package Thickness	A2	2.05	—	—
Standoff §	A1	0.10	—	0.30
Overall Width	E	10.30 BSC		
Molded Package Width	E1	7.50 BSC		
Overall Length	D	17.90 BSC		
Chamfer (optional)	h	0.25	—	0.75
Foot Length	L	0.40	—	1.27
Footprint	L1	1.40 REF		
Foot Angle Top	φ	0°	—	8°
Lead Thickness	c	0.18	—	0.33
Lead Width	b	0.31	—	0.51
Mold Draft Angle Top	α	5°	—	15°
Mold Draft Angle Bottom	β	5°	—	15°

Notes:

- Pin 1 visual index feature may vary, but must be located within the hatched area.
- § Significant Characteristic.
- Dimensions D and E1 do not include mold flash or protrusions. Mold flash or protrusions shall not exceed 0.15 mm per side.
- Dimensioning and tolerancing per ASME Y14.5M.

BSC: Basic Dimension. Theoretically exact value shown without tolerances.

REF: Reference Dimension, usually without tolerance, for information purposes only.

8.3 SOIC 300mil (SO) Land Pattern

28-Lead Plastic Small Outline (SO) – Wide, 7.50 mm Body [SOIC]

For the most current package drawings, please see the Microchip Packaging Specification located at <http://www.microchip.com/packaging>.

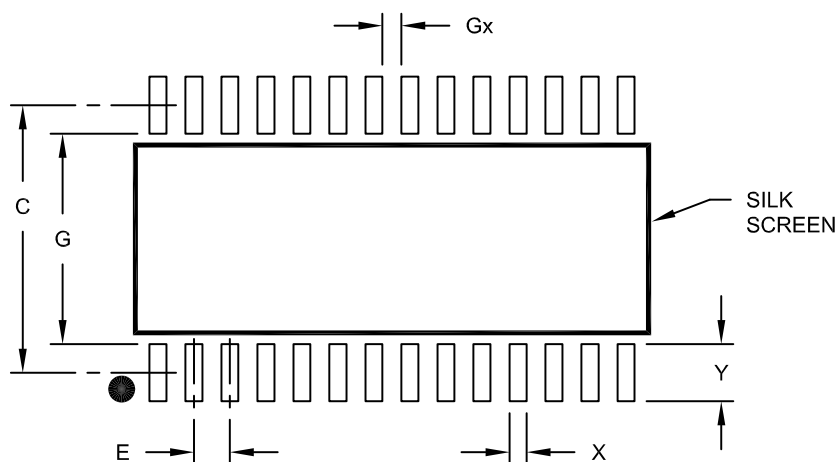

RECOMMENDED LAND PATTERN

		Units	MILLIMETERS		
Dimension Limits			MIN	NOM	MAX
Contact Pitch	E		1.27 BSC		
Contact Pad Spacing	C			9.40	
Contact Pad Width (x28)	X				0.60
Contact Pad Length (x28)	Y				2.00
Distance Between Pads	Gx		0.67		
Distance Between Pads	G		7.40		

Notes:

1. Dimensioning and tolerancing per ASME Y14.5M.
BSC: Basic Dimension. Theoretically exact value shown without tolerances.

8.4 QFN-S (MM) Package

28-Lead Plastic Quad Flat, No Lead Package (MM) – 6x6x0.9 mm Body [QFN-S] with 0.40 mm Contact Length

For the most current package drawings, please see the Microchip Packaging Specification located at <http://www.microchip.com/packaging>.

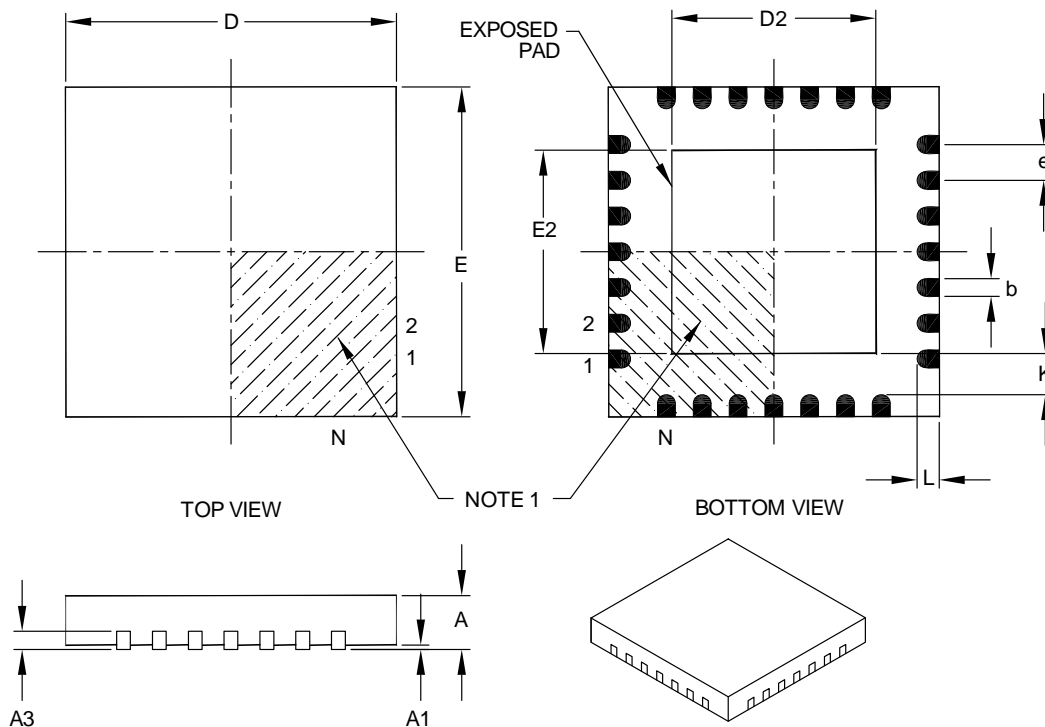

		Units	MILLIMETERS		
Dimension Limits			MIN	NOM	MAX
Number of Pins	N		28		
Pitch	e		0.65 BSC		
Overall Height	A		0.80	0.90	1.00
Standoff	A1		0.00	0.02	0.05
Contact Thickness	A3		0.20 REF		
Overall Width	E		6.00 BSC		
Exposed Pad Width	E2		3.65	3.70	4.70
Overall Length	D		6.00 BSC		
Exposed Pad Length	D2		3.65	3.70	4.70
Contact Width	b		0.23	0.38	0.43
Contact Length	L		0.30	0.40	0.50
Contact-to-Exposed Pad	K		0.20	—	—

Notes:

- Pin 1 visual index feature may vary, but must be located within the hatched area.
- Package is saw singulated.
- Dimensioning and tolerancing per ASME Y14.5M.
 - BSC: Basic Dimension. Theoretically exact value shown without tolerances.
 - REF: Reference Dimension, usually without tolerance, for information purposes only.

8.5 QFN-S (MM) Land Pattern

28-Lead Plastic Quad Flat, No Lead Package (MM) – 6x6x0.9 mm Body [QFN-S] with 0.40 mm Contact Length

For the most current package drawings, please see the Microchip Packaging Specification located at <http://www.microchip.com/packaging>.

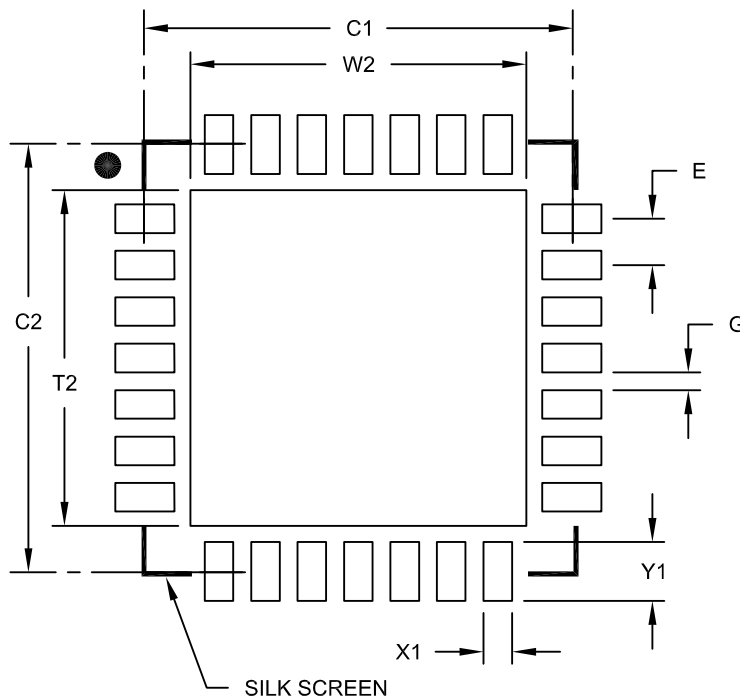

RECOMMENDED LAND PATTERN

Dimension Limits	Units	MILLIMETERS		
		MIN	NOM	MAX
Contact Pitch	E	0.65 BSC		
Optional Center Pad Width	W2			4.70
Optional Center Pad Length	T2			4.70
Contact Pad Spacing	C1		6.00	
Contact Pad Spacing	C2		6.00	
Contact Pad Width (x28)	X1			0.40
Contact Pad Length (x28)	Y1			0.85
Distance Between Pads	G	0.25		

Notes:

1. Dimensioning and tolerancing per ASME Y14.5M.
BSC: Basic Dimension. Theoretically exact value shown without tolerances.

9.0 Ordering Information

TA	Package		Part Number	SKU
-40°C to +85°C	SPDIP (SP)	Tube	STN1110-I/SP	365101
	SOIC (SO)	Tube	STN1110-I/SO	365111
	QFN-S (MM)	Tube	STN1110-I/MM	365121

Appendix A: Revision History

Revision A (October 22, 2010)

Initial release of this document.

Revision B (July 13, 2012)

Revised the “Overview”, “Feature Highlights”, and “Typical Applications” sections. Added current capability ratings to the “Pinout Summary” table and relevant pin descriptions. Changed recommended connections for unused pins. Deleted last sentence of NVM Reset Input description (RST_NVM needs a pullup whether an LED is connected or not). Added “Recommended ANALOG_IN Voltage Source Impedance” (R_{IN}) specification to “Input Pin Specifications” table. Updated schematics, and added short descriptions to the “Recommended Minimum Connection” and “Typical Configuration” sections. Minor typographical and formatting changes.

Revision C (February 6, 2018)

This revision includes minor typographical and formatting changes throughout the datasheet text. Other changes are listed in the table below.

Section	Description of changes
1.0 “Overview”	Updated FRPM name
4.0 “Pinout”	Updated GP labels to pinout diagrams
4.1 “Pinout Summary”	Added Note 1 (warning about excessive power cycling) Added GPxx section
4.2 “Detailed Pin Descriptions”	Added GPxx section
5.0 “Guidelines for Getting Started with STN1110”	Reordered the subsections
5.8 “NVM Reset Input”	Added description of the pin operation
5.9 “Power and Sleep Considerations”	New section
6.1 “Recommended Minimum Connection”	New Section
6.2.1 “STN1110 IC”	New Section
6.2.2 “Voltage Sense”	New Section
6.2.3 “LEDs”	New Section
6.2.4 “OBD Port Connector and ESD protection”	New Section
6.2.5 “Overvoltage Protection Circuit”	New Section
6.2.6 “Power Supplies”	New Section
6.2.7 “Switched Power Control”	New Section
6.2.8 “ISO 9141/ISO 14230 Transceiver”	New Section
6.2.9 “High-Speed CAN Transceiver”	New Section
6.2.10 “Alternative (MCP2551) HS-CAN Transceiver”	New Section
6.2.11 “SAE J1850 Transceiver”	New Section

STN1110

Revision D (February 28, 2018)

6.2.11 "SAE J1850 Transceiver"	Correct BUS- with active high, changed to pull-down
6.2.8 "ISO 9141/ISO 14230 Transceiver"	Updated ISO schematic with separate pull ups
4.0 "Pinout"	Updated J1850 BUS- on IC
6.1 "Recommended Minimum Connection"	Updated J1850 BUS- on IC
6.2.1 "STN1110 IC"	Updated J1850 BUS- on IC
6.2.9 "High-Speed CAN Transceiver"	Changed standby pin configuration

Appendix B: Contact Information

OBD Solutions LLC
11048 N 23rd Ave Ste 101
Phoenix, AZ 85029
United States

Phone: +1 623.582.2366
Email: sales@obdsol.com
Web: www.obdsol.com